

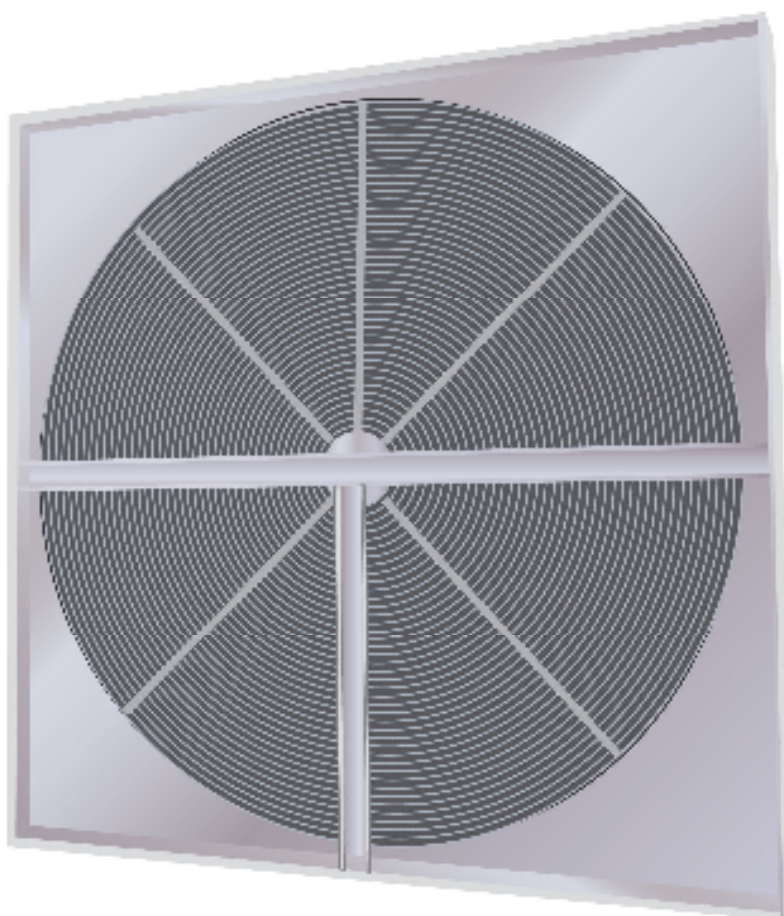

HEAT EXCHANGER

# MODEL B

**INSTALLATION & MAINTENANCE MANUAL**



## Committed to Excellence

---

HEATEX AB

Tommarpsvägen 46, SE-231 65 Trelleborg, Sweden

Phone: +46 410 71 05 00, Fax: +46 410 71 05 29

Internet: [www.heatex.com](http://www.heatex.com)



## Table of contents

MLN100420

<b>DECLARATION OF INCORPORATION</b>	<b>3</b>
<b>GENERAL</b>	<b>4</b>
<b>BY DELIVERY</b>	<b>4</b>
<b>TRANSPORT</b>	<b>4</b>
<b>STORAGE</b>	<b>5</b>
<b>INSTALLATION</b>	<b>5</b>
<b>ADJUSTMENTS</b>	<b>6</b>
<b>MAINTENANCE</b>	<b>7</b>
<b>MATRIX</b>	<b>7</b>
<b>HYBRID/ADSORPTION MATERIAL</b>	<b>7</b>
<b>BRUSH SEALANTS</b>	<b>7</b>
<b>CONTROLLER</b>	<b>8</b>
<b>APPLICATION LIMITS</b>	<b>8</b>
<b>TROUBLESHOOTING</b>	<b>8</b>
<b>SUPPORT</b>	<b>9</b>
<b>PLEASE CONTACT US:</b>	<b>9</b>



Original

## Declaration of Incorporation

**Heatex AB  
Tommarpsvägen 46  
SE-231 65  
Trelleborg  
Sweden**

Description and identification of the partly completed machinery:

**Rotary heat exchanger model B with casing and with a drive unit.**

The following essential requirements of EC Machinery Directive 2006/42/EC have been applied and fulfilled:

1.1.2, 1.2.1, 1.2.3, 1.2.4.1, 1.2.4.2, 1.2.4.3, 1.2.6, 1.3.1, 1.3.2, 1.3.4, 1.3.7, 1.3.8, 1.3.8.1, 1.3.8.2, 1.4.1, 1.4.2.1, 1.4.2.2, 1.4.2.3, 1.4.3, 1.5.1, 1.5.2, 1.5.4, 1.5.5, 1.5.6, 1.6.1, 1.6.3, 1.7.1, 1.7.3, 1.7.4, 1.7.4.1, 1.7.4.2, 1.7.4.3

The relevant technical documentation has been compiled in accordance with Annex VII, Part B of EC Machinery Directive 2006/42/EC. We undertake, in response to a reasoned request, to supply it in electronic form to the market surveillance authorities within a reasonable period.

The party authorised to compile the technical documentation is:

Michael Norberg, Product manager rotary heat exchangers

The partly completed machinery must not be put into service until the final machinery into which it is to be incorporated has been declared in conformity with the provisions of the Machinery Directive.

Christer Tännander CEO

Signature

Trelleborg, 20 April 2010



## General

A rotary heat exchanger with casing and drive is "partly completed machinery" as defined in Directive 2006/42/EC. This product is delivered in compliance with the Directive 2006/42/EC but when installed in the complete machinery it is up to the installer to make sure that the final product is in compliance with the directive.

Special attention should be paid to sharp edges (risk of cuts) and that when the wheel is rotating the rotating parts may cause injuries.

The surfaces of the drive motor and gear can be hot and attention should also be paid to the risk of burn injuries.

The sound level from the heat exchanger is less than 70 dB (A).

## By delivery

Before installation the following should be checked:

- Check if there are any signs of transport damage before accepting the goods.
- Has the right exchanger been delivered? Check type, design, size and options.
- How is the exchanger to be positioned?
- In case of any damage please report this in writing by fax or email as soon as possible.

## Transport

- The weight of the unit can be found on the product label attached to the unit.
- Always transport the exchanger vertically.
- Lift the exchanger in the upper two aluminium rods alternatively the gables according to picture 1.
- It is important that all transport is carried out by qualified staff.



All transport is to be carried out by qualified staff.

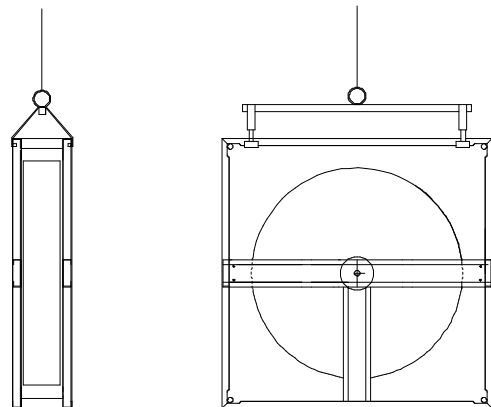

Picture 1. Lift the casing in the gables.



## Storage

There are no other requirements for storage than a horizontal even surface and out of weather. Please note that an uneven surface can warp the cassette and affect the factory adjustments.

Always make sure that the heat exchanger is supported and secured during transport, handling, storage and installation so it can not fall over and cause damage or injuries.



Heat exchanger may fall over if not secured.

Please observe that there may be sharp edges and a risk for cuts so we recommend that gloves are used when the heat exchanger is handled.



Use gloves when handling the heat exchanger.

## Installation

- The casing is self supporting but cannot take up extra load e. g. ducts.

- Place the rotor on a horizontal surface since an uneven surface can warp the casing and affect the factory adjustments.
- Make sure that the front- and back plates of the casing are installed perpendicular to the horizontal bottom surface. If not the casing may interfere with the movement of the rotor wheel
- In case of horizontal rotors support is needed for the frame and centre girder. Also check that rotor is ordered and manufactured as a horizontal rotor. Rotor may only be installed either in a vertical or a horizontal position, not at an angle.
- Avoid diagonal flow since this can affect the rotation and drive of the wheel. Heatex AB recommends the air flow to be perpendicular to the rotor.
- The rotor is designed for counter flow only, co-current flow will decrease efficiency and reduce the rotors self cleaning.
- Prior to initial operation please make sure no objects are blocking the rotors free movement. The rotor should move evenly and smoothly around its shaft.



Placing the unit on an uneven surface may wrap the casing.

- Drive motor if delivered with controller is pre-wired and 230V should just be wired to the controller. Constant speed motors are without wiring. It is important that all electrical work is carried out by qualified staff. Please see enclosed documentation and/or wiring Picture 2.



Picture 2. Wiring diagram constant drive  $\Delta/Y$  220/380V.

- If the unit is delivered with a variable speed drive, read the corresponding controller documentation.



### **IMPORTANT!**

All electrical work must be carried out by qualified staff.

## Adjustments

- If necessary adjust the brush sealants to minimize leakage.
- If the belt slides adjust belt tension. The round belt as well as Powerbelt should have a tension of 1-2% (i.e. belt should be 1-2% shorter than the length it travels). For Powerbelt remove 1 link per meter belt to get correct tension.



## Maintenance

### Matrix

To secure the function and performance, the face of the rotor has to be inspected regularly for dust and dirt. In most cases the self cleaning due to counter flow and rotation of the matrix makes manual cleaning unneeded. If the self cleaning is insufficient dirt or/and dust can appear in the matrix. Depending on the degree of soiling it is recommended to use following cleaning:

1. For only a small amount of easily removable dirt Heatex AB recommends to use a vacuum cleaner.
2. For heavier dirt it is also possible to use compressed air but with caution.
3. Firmly attached dirt in the rotor is easiest removed by using hot water and a mild detergent.

### Hybrid/Adsorption material

The adsorption material is aluminium coated with a silica gel based coating. There is a small amount of surplus material that might leave the matrix during the first time of usage. This will NOT affect the hygroscopic properties. The excess powder is harmless and easy to remove using a vacuum cleaner.

The hybrid wheel properties are obtained by a combination of a flat strip of adsorption material consisting of silica gel

coated aluminium and a corrugated aluminium strip which result in a moisture transfer capacity in between that of an aluminium matrix and an adsorption matrix.

Just as for the adsorption wheel a small amount of surplus material may leave the matrix during the first time of usage.

### Powerbelt

The Powerbelt is subjected to natural stretching which may require shortening of the belt. Tension of the belt must be checked after the first 24-48 hours in operation to secure the rotational function of the wheel.

The belt is made of links that can easily be added or removed without any tools. By just twisting the belt it is possible to open it and remove links to shorten the belt until correct length and belt tension is obtained. Belt tension should be 1-2% (i.e. belt length 1-2% shorter than travelled length). For Powerbelt remove 1 link per meter belt to get correct tension.

### Round belt

Also the round belt may need adjustment. The belt is joined together with a special joining pin and it is easy to shorten the belt and join it together again. Belt tension should be 1-2%.

### Brush sealants

Tightness between brush sealants and casing has to be checked during inspection. The brush sealants are easily adjusted by unscrewing the screws and



moving the brush sealant into the right position.

### Controller

For further information regarding rotary heat exchanger equipped with controller, please see corresponding controller instructions.

### Application limits

Recommended temperature limits for rotary heat exchanger:

Min: -40°C  
Max: 65°C

It is however important not to exceed the temperature limits on mounted components:

Component	Min	Max
Bearing temp.	-40°C	110°C
Belt temp.*	-40°C	66°C
Motor temp.**	-20°C	40°C
Emotron Controller	-30°C	40°C
Standard Controller	0°C	45°C

\* Powerbelt max 110°C

\*\*Thermo contacts release at 150°C inner temp.

Temperature inside casing is approximately the mean temperature of supply and exhaust air temperatures.

Recommended pressure drop and differential pressure for rotary heat exchanger:

- Pressure drop max 300 Pa
- Pressure drop recommended 100-200 Pa

- Differential pressure max 600 Pa.

### Troubleshooting

If the rotary heat exchanger does not rotate properly please follow these steps to solve/locate the problem.

1. If the motor runs properly please jump to step 5.
2. If there is a controller installed please check controller technical specifications, chapter troubleshooting.
3. If there is a constant drive installed:  
Please check that the drive is correctly connected. Note that all electrical maintenance and installation must be performed by qualified personal.
4. Disconnect the belt, is the motor running correctly?
5. If the belt is sliding please tighten the belt according to maintenance instruction.
6. Rotate the wheel by hand (belt disconnected from the motor). Is it possible to smoothly rotate the wheel or does the wheel interacts with the casing? If there is mechanical friction, please locate the position.
7. Make sure the connected ducts do not press on the casing making it squeeze against the wheel. Make sure the diagonal measures of the casing side where the motor is positioned are equal.



## **Support**

For questions or other requirements regarding this product, please state order number, product name and message.

Heatex AB is available for your support during office hour (0800am – 0430pm weekdays).

### **Please Contact us:**

Heatex AB  
Tommarpsvägen 46  
SE-231 65 Trelleborg, Sweden  
Telephone +46 410 71 05 00  
Telefax +46 410 71 05 29  
E-mail [info@heatex.com](mailto:info@heatex.com)  
[www.heatex.com](http://www.heatex.com)